

## PFFE 7131 Motorized display lift

Article number (SKU)  
Colour

7371314  
Silver

### Key Benefits

- Modular
- Quick and easy installation
- Solid construction
- Suitable for heavy displays

Vogel's' motorized display lift is part of the modular Connect-it system. Together with the PFA 9134, PFF 7025 or PFT 8525 you can create floor or mobile solutions which allows educators and presenters to bring their content to new heights.

**Schools, universities and companies are rapidly modernizing their classrooms and meeting rooms. Blackboards and whiteboards are being replaced by large interactive displays in order to create an immersive and engaging environment. Vogel's' motorized display lift allows educators and presenters to bring their content to new heights. Whether your audience are children in kindergarten or the board of directors, they will always be able to interact with the content thanks to the display lift's unique 600 mm travel. Connect-it compatible**

Vogel's motorized lift is a fresh component in our modular Connect-it Series and therefore compatible with our bars, strips and accessories. The motorized display lift can be mounted directly to the floor. With the optional wall bracket you can also secure this floor solution to the wall. Of course the lift can also be mounted on the Connect-it floor plate or a trolley.

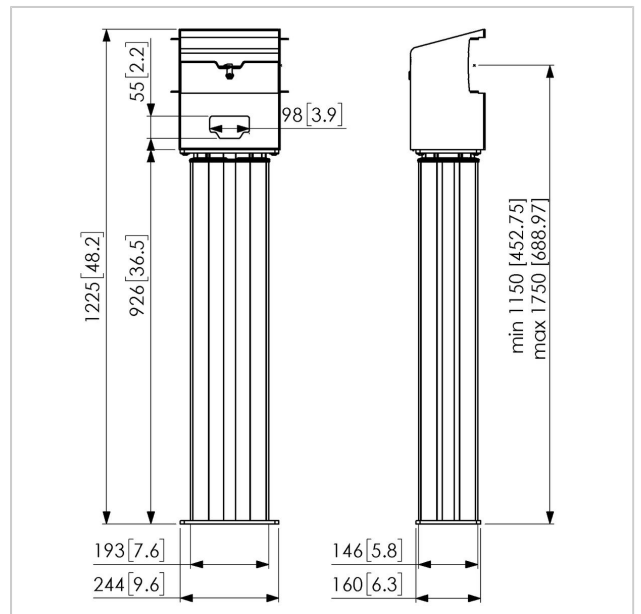



## PFFE 7131 Motorized display lift

[www.vogels.com](http://www.vogels.com)

VOGEL'S HOLDING BV 2019 (c) All rights reserved.  
Subject to printing errors, technical and price amendments.  
Date: 2019-02-13

## Specifications

Product type number	PFFE 7131
Article number (SKU)	7371314
Colour	Silver
EAN single box	8712285337185
TÜV certified	Yes
Guarantee	5 years
Min. screen size (inch)	50
Max. screen size (inch)	90
Max. weight load (kg)	150
Max. distance to floor - center display (mm)	1750
Min. distance to floor - center display (mm)	1150
Motorized	True
Product group	Motorized lift module
Remote controlled	Yes
Travel	600
Product line	Connect-it

