

Monitor Arm Twin STOCKHOLM

In order to achieve a correct mounting of this product, you are advised to read and follow the instructions step by step. If there are incomprehensible steps, please let us know and we will get back to you. **Note! All necessary parts are found in 3 separate boxes.**

Part Check-List

①		x1	③		x2
STANDARD CLAMP					
A1		x1			
IN-DESK CLAMP					
B1		x1	④		x8**
B2		x1	⑤		x1
B3		x1	⑥		x1
B4		x1	⑦		x1
B5		x2	⑧		x8
B6		x1	⑨		x2

Note! Might be pre-mounted**

STEP 1 FOR "STANDARD CLAMP" - 438-EA105

- *Adhere pad ① to the bottom side of the clamp ①. Fasten clamp to the table using the handle. Consider re-positioning the clamp bracket in accordance to the table thickness using the guidelines below.

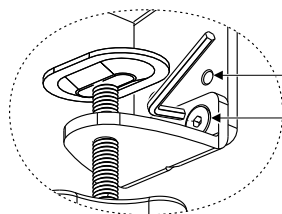
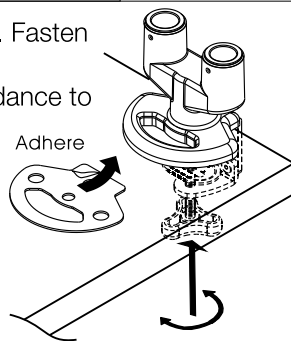

Table thickness guide
 0-36 mm (upper position)
 9-56 mm (lower position)

*If you do not intend to mount the final product to the edge of a table, then go to "IN-DESK CLAMP".



Adhere

www.kondator.se

Revised 190418

STEP 1 FOR "IN-DESK CLAMP" - 438-EA105

- Use Allen Key ⑥ to loosen the three screws and remove the pre-assembled bracket.

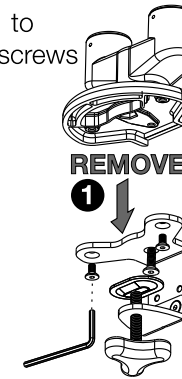

REMOVE
1

- Use the same three screws to fasten the In-Desk bracket ③ and long bolt ②.

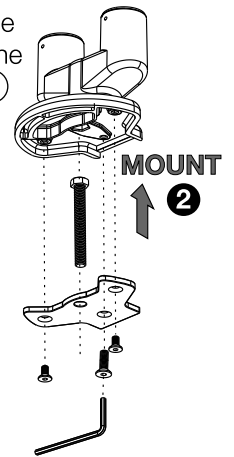

MOUNT
2

- Adhere pad ① to the bottom of the clamp, through the long bolt. Insert the re-assembled clamp through the hole in the table. Secure the clamp using all remaining parts ③-⑥. Be sure to tighten both nuts.

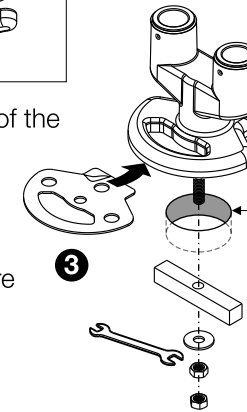

Table hole guide
 • 20-50* mm (diameter)
 • 0-36 mm (table thickness)

*If you intend to pass the cables through the hole, then Ø50 mm is appropriate.

STEP 2 - 438-LC50

Insert both monitor arms ③ into the clamp and fasten the two cup point socket screw ④ with Allen key ⑦. Adjust the tension of the rotation to your need.

To keep the arms completely rigid, fasten the small cup point socket screws as tight as possible while maintaining the intended position.

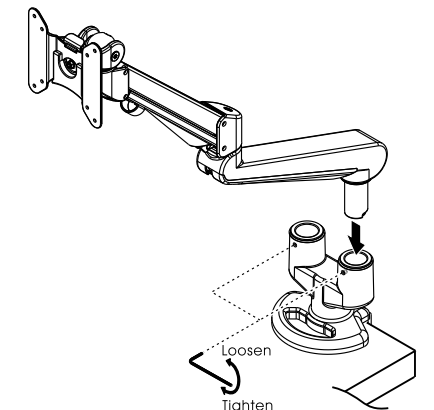

Loosen
Tighten

Assembly Guide

STEP 3

Remove the VESA plate by pinching the grey plastic tab to release the lock, then pull the VESA plate upwards to separate it from the arm. Repeat for the second arm.

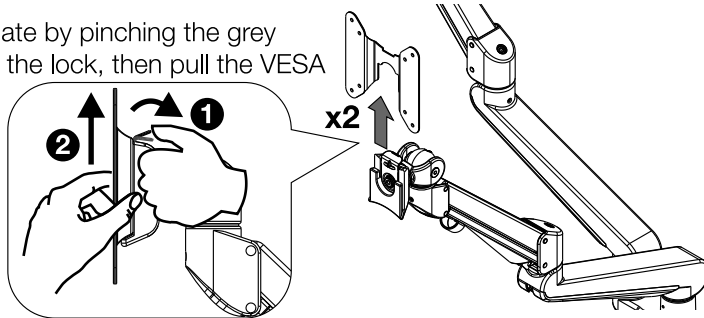

STEP 4

Place the monitor face down on a flat surface. Align the VESA plate holes with the holes on the back of the monitor. Attach the monitor screen using the hexagonal screws (8).

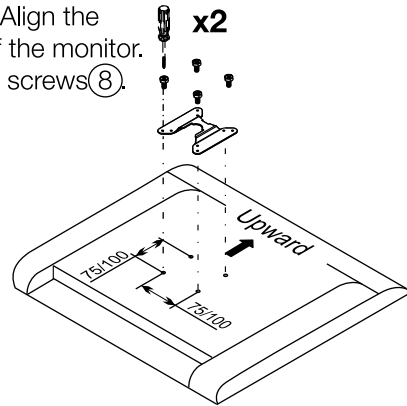
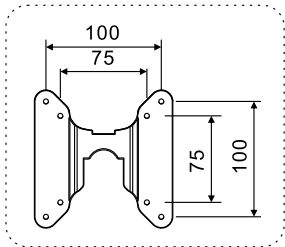

STEP 5

Slide the monitor (with VESA plate) onto the arm and make sure it "clicks" securely into position.

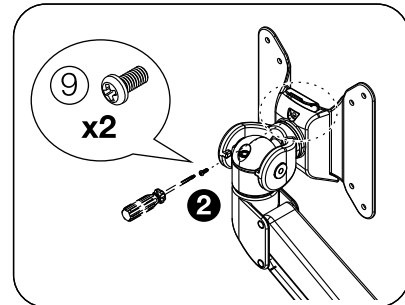
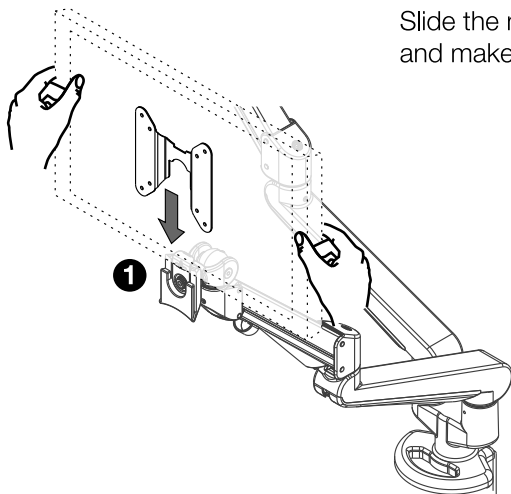

Assembly Guide

STEP 6

Unattach the cable collector and route the cables through. Once satisfied, re-attach the collector back into place. Proceed by continuing the routing through the cable clip.

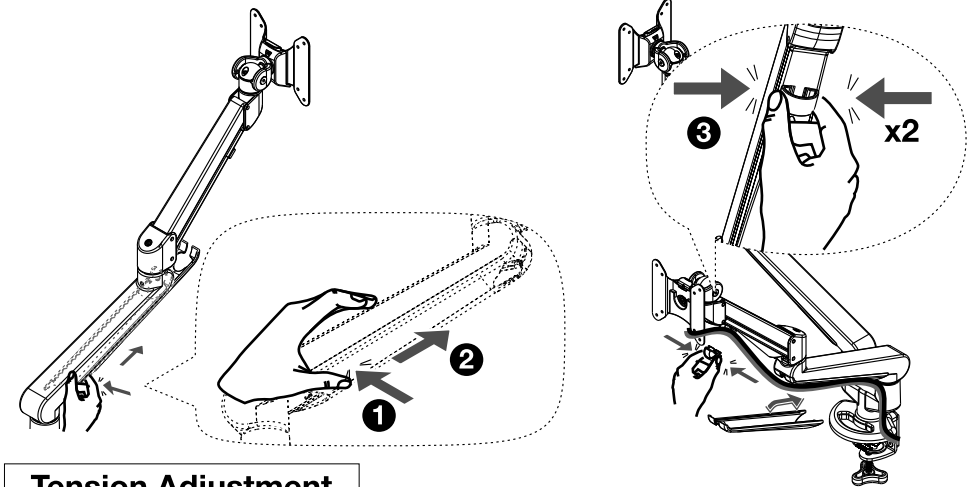

Tension Adjustment

Adjustment:

Use the Allen key provided to adjust the tension to correspond to the weight of the desired monitor. Turn the Allen key (5) counter-clockwise to adjust for heavier monitors; clockwise for lighter monitors. Once the adjustment is done, the monitor should be experienced as weightless and the monitor should remain in any position without dropping nor rising.

Caution:

Support and hold on to the arm while adjusting the tension.

When the joint loosens, use Allen key (5) to tighten the joint. Clockwise to tighten for heavier monitors; Counter-clockwise to loosen.

Recommendations:

- 3-8 kg (6.6-17.6 lbs).
- The products loading capacities are based on monitors' center of gravity less than 3 cm from the end of the VESA interface.
- Loading capacity could be reduced if the monitor size is greater than 26 inches or if the thickness exceeds 5.5 cm.
- All product specifications in catalogues are subject to change without notice.

