

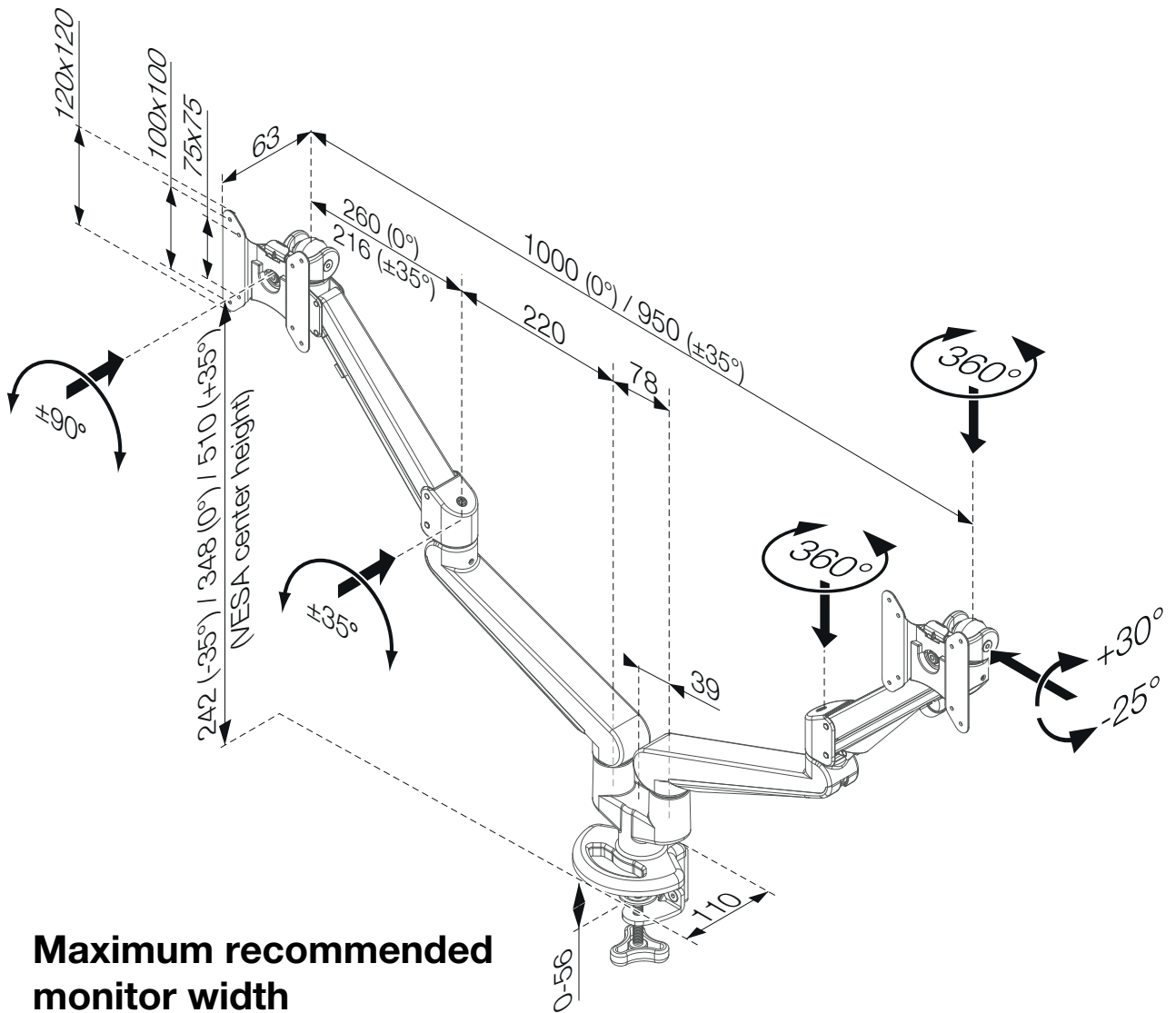

- 438-LC52
- 438-LC52W
- 438-LC52B

## Monitor Arm STOCKHOLM Twin 3-8 kg, Gas Spring

### Oriented View



### Maximum recommended monitor width

- (2x) 992 mm

### Alternative grommet clamp

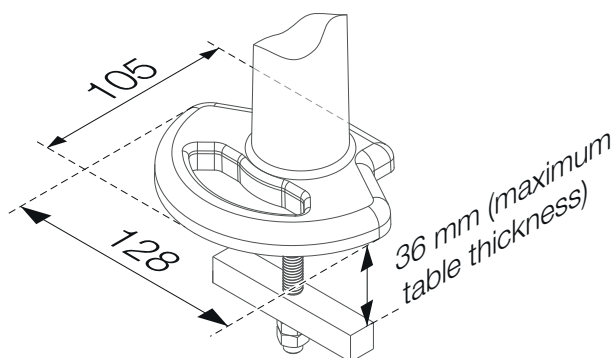

### Range for table thickness

- 16-50.8 mm (regular clamp)
- 0-36 mm (grommet clamp)